



Province of the
EASTERN CAPE
EDUCATION

**NATIONAL
SENIOR CERTIFICATE**

GRADE 12

JUNE 2021

**LIFE SCIENCES
(EXEMPLAR)**

MARKS: 150

TIME: 2½ hours

This question paper consists of 19 pages.

INSTRUCTIONS AND INFORMATION

Read the following instructions carefully before answering the questions.

1. Answer ALL the questions.
2. Write ALL the answers in your ANSWER BOOK.
3. Start the answers to EACH question at the top of a NEW page.
4. Number the answers correctly according to the numbering system used in this question paper.
5. Present your answers according to the instructions of each question.
6. ALL drawings must be done in pencil and labelled in blue or black ink.
7. Draw diagrams, flow charts or tables only when asked to do so.
8. The diagrams in this question paper are NOT necessarily drawn to scale.
9. Do NOT use graph paper.
10. You must use a non-programmable calculator, protractor and a compass where necessary.
11. Write neatly and legibly.

SECTION A**QUESTION 1**

1.1 Various options are given as possible answers to the following questions. Choose the correct answer and write only the letter (A–D) next to the question number (1.1.1–1.1.9) in the ANSWER BOOK, for example 1.1.10 D.

1.1.1 Which of the following cell structures is the site of DNA replication?

- A Nucleus
- B Ribosome
- C Nucleolus
- D Rough endoplasmic reticulum

1.1.2 One of the functions of the amnion is to ...

- A serve as a reserve food supply.
- B give rise to the placenta.
- C prevent the developing foetus from moving about.
- D enclose the fluid that protects the embryo against injury.

1.1.3 Which ONE of the following correctly describes a difference between DNA and RNA?

	DNA	RNA
A	Deoxyribose sugar	Ribose sugar
B	Uracil	Thymine
C	Single stranded	Double stranded
D	Different number of cytosine and guanine nitrogen bases	Same number of cytosine and guanine nitrogen bases

1.1.4 The ABO blood group system of humans is an autosomal trait that has three alleles as follows: I^A , I^B , i .
In this system four different blood groups exist. They are groups A, B, AB and O.

In a family of four children, each child has different blood group with respect to this gene.

The phenotypes of the parents must be ...

- A AB and O.
- B A and B.
- C B and AB.
- D O and B.

- 1.1.5 A pair of homologous chromosomes involved in normal meiosis carries the alleles as shown below.

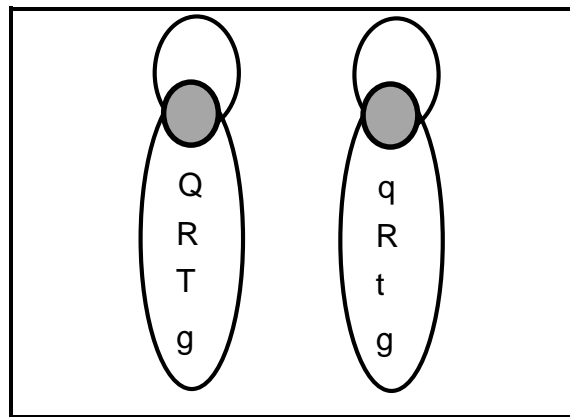

Chromosomes detected in eggs would include:

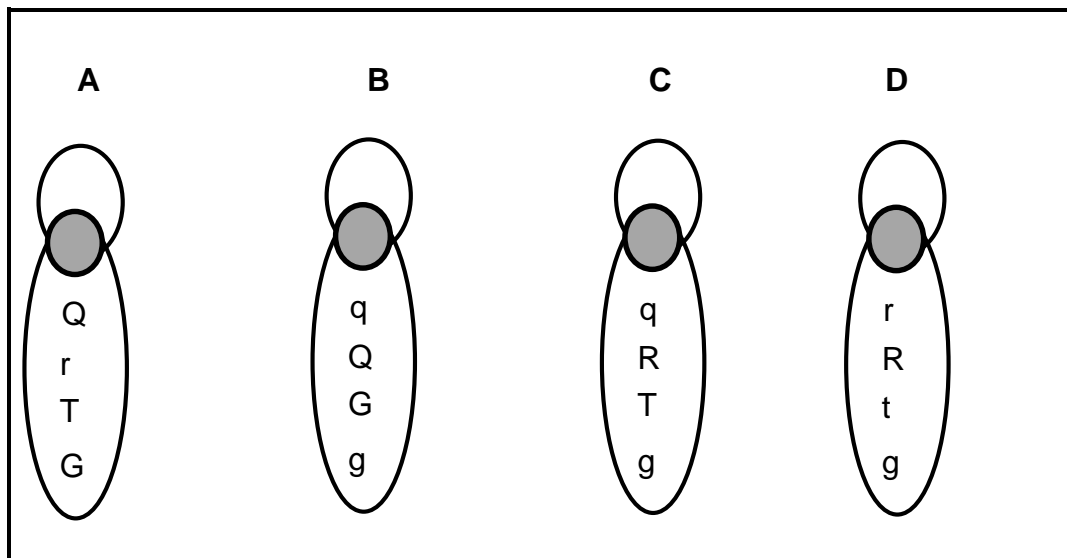

- 1.1.6 A homozygous recessive individual is crossed with a heterozygous individual.

What is the chance of getting an offspring with a homozygous recessive genotype?

- A 25%
- B 50%
- C 75%
- D 100%

- 1.1.7 The amount of DNA in various types of chicken was measured. The following results were obtained.

CELL TYPE	PICTOGRAMS OF DNA
R	2,55
S	2,61
X	1,26
Y	2,54

From this data it is reasonable to conclude that the cell most likely to be a sperm is ...

- A cell type R.
- B cell type S.
- C cell type X.
- D cell type Y.

- 1.1.8 Study the diagram below.

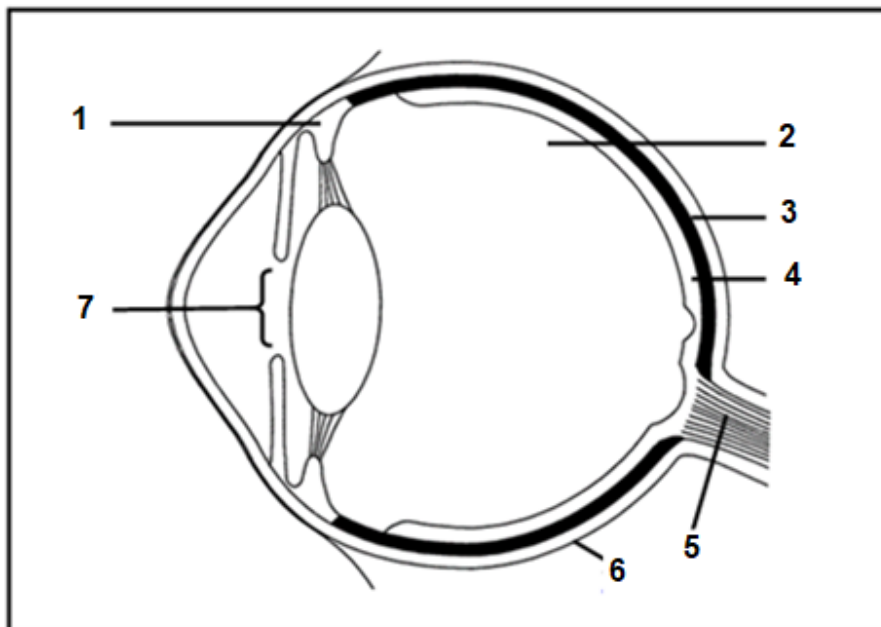

Which ONE of the following correctly represents the labelled structures?

- A 3 – blind spot; 4 – choroid
- B 2 – vitreous humour; 1 – suspensory ligaments
- C 5 – optic nerve; 7 – pupil
- D 6 – conjunctiva; 3 – yellow spot

1.1.9 The DNA profiles of a mother and father and four children are shown in the diagram below.

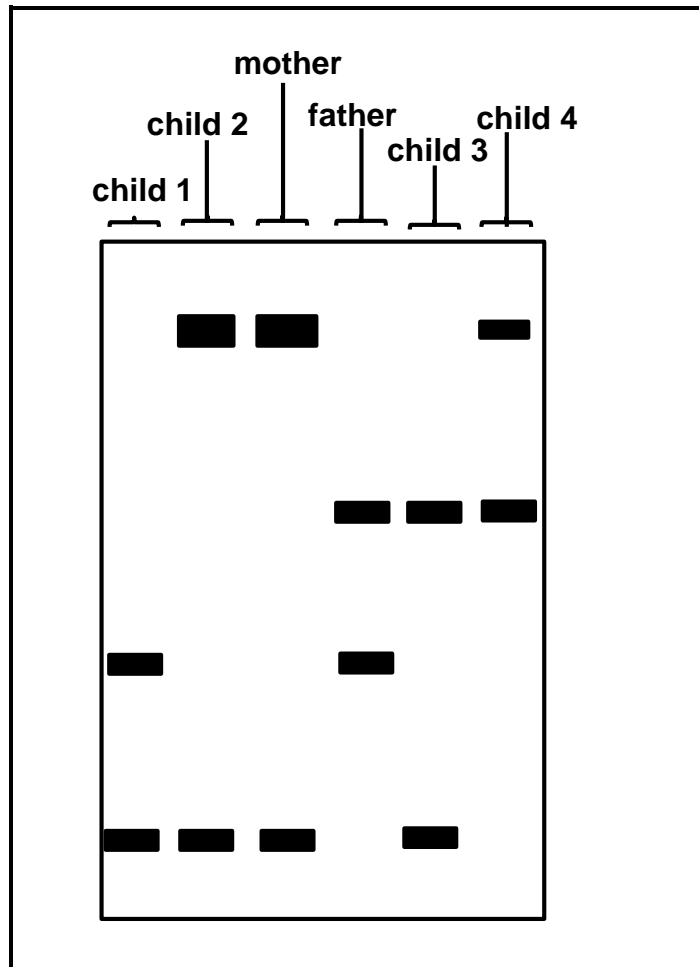

Which child is LEAST LIKELY to be the biological offspring of this couple?

- A Child 1
- B Child 2
- C Child 3
- D Child 4

(9 x 2) (18)

1.2 Give the correct **biological term** for each of the following descriptions. Write only the term next to the question number (1.2.1–1.2.7) in the ANSWER BOOK.

- 1.2.1 A hollow ball of cells formed from the zygote
- 1.2.2 The type of fertilisation associated with vivipary
- 1.2.3 The bonds between amino acids in a protein molecule
- 1.2.4 A blood vessel in the umbilical cord that transports nutrients to the foetus
- 1.2.5 A section of DNA that carries the code for a particular trait
- 1.2.6 Small tubes placed in the tympanic membrane to drain liquid from the middle ear
- 1.2.7 Tangled network of chromosomes located within the nucleus

(7 x 1) (7)

1.3 Indicate whether each of the statements in COLUMN I applies to **A ONLY**, **B ONLY**, **BOTH A and B** or **NONE** of the items in COLUMN II. Write **A only**, **B only**, **both A and B** or **NONE** next to the question number (1.3.1–1.3.3) in the ANSWER BOOK.

COLUMN I		COLUMN II	
1.3.1	A type of development in birds in which the young are capable of moving around soon after hatching	A:	Altricial development
		B:	Precocial development
1.3.2	All genes in all the chromosomes of a species	A:	Genotype
		B:	Genome
1.3.3	The advantage of the amniotic egg	A:	Provides nutrition
		B:	Protects against dehydration

(3 x 2) (6)

- 1.4 In tomato plants the colour of the stem is controlled by two alleles, purple (**P**) and green (**p**). The type of leaf is also controlled by two alleles, cut leaf (**L**) and potato type leaf (**l**)

The Punnet square below shows the results of a cross between a plant with purple stem and cut leaves and a plant with a green stem and potato type leaves.

Parent 1				
Gametes	PL	Pl	pL	pl
pl	PpLl	(Z)	ppLl	ppll

- 1.4.1 Give the:

- (a) Genotype of parent 1 (2)
- (b) Genotype of plant Z (1)

- 1.4.2 What percentage of plants have green stems with potato type leaves? (2)

1.5 The diagram below represents a reflex arc.

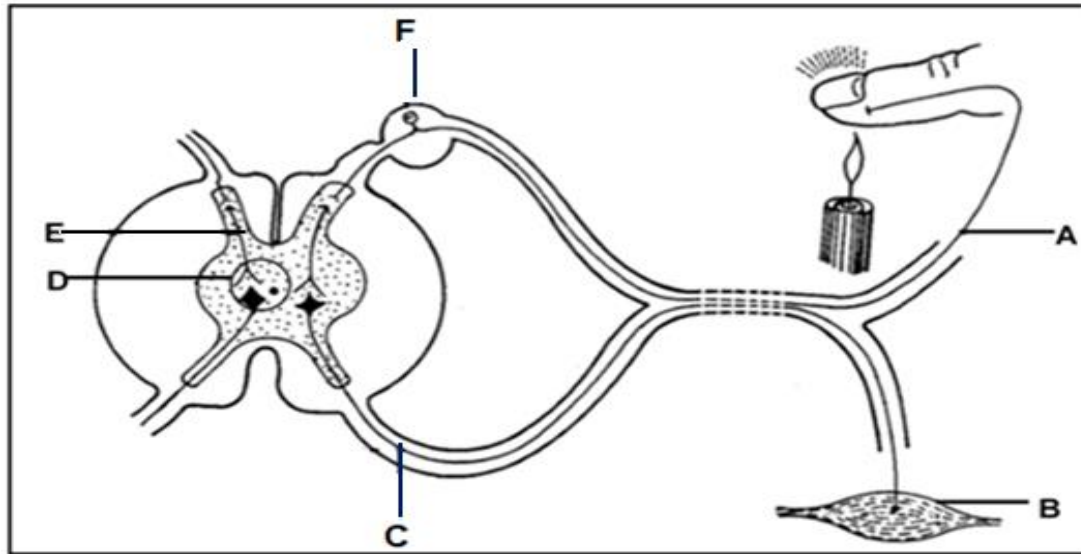

1.5.1 Give the LETTER and NAME of the part that:

- (a) Transmits impulses to the cell body (2)
- (b) Controls one-directional transmission of impulses (2)
- (c) Transmits impulses from the sensory neuron to the correct motor neuron (2)

1.5.2 Give only the LETTER of the:

- (a) Effector (1)
- (b) Neuron that is damaged when a person is able to feel pain, but cannot react to stimulus (1)

1.6 The diagram below represents the structure of the male reproductive system.

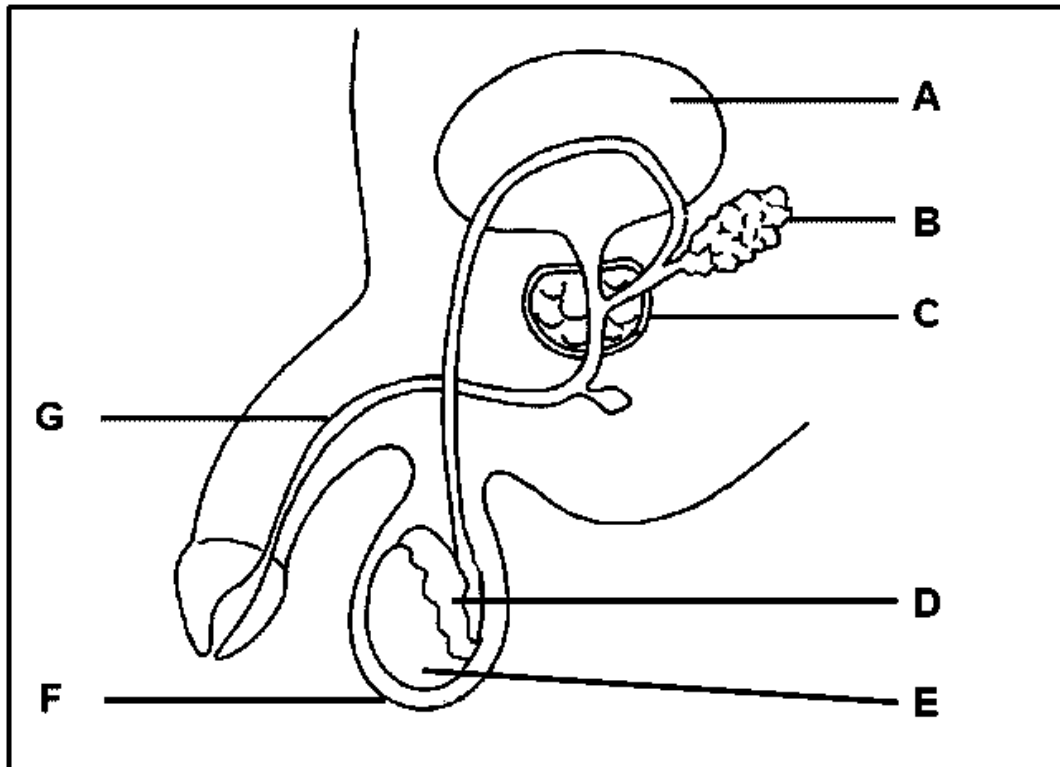

1.6.1 Identify:

- (a) C (1)
- (b) D (1)

1.6.2 Give the LETTER and NAME of the part:

- (a) That carries sperm and urine out of the body (2)
- (b) Which produces the male sex hormone testosterone (2)

TOTAL SECTION A: 50

SECTION B

QUESTION 2

2.1 The following diagram represents stages of protein synthesis.

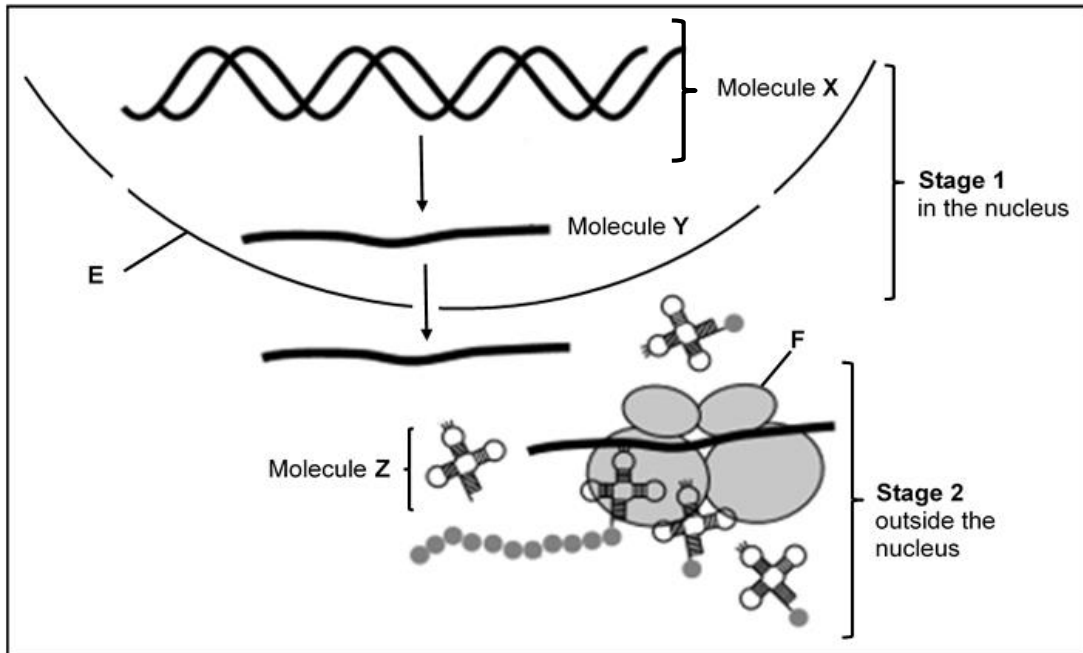

2.1.1 Identify:

- (a) Structure **E** (1)
- (b) Molecule **X** (1)

2.1.2 Give the function of molecule **Y** in protein synthesis. (1)

2.1.3 Name and describe the events occurring at stage **2** as shown in the above diagram. (6)

2.1.4 The sequence of nitrogenous bases shown below belongs to a section of a DNA molecule.

AAA-GTA-CTG-CGC

- (a) What does **A** represent in this sequence? (1)
- (b) Give the corresponding sequence of nitrogenous bases that will be found in molecule **Y**. (2)
- (c) Give the corresponding anticodon that corresponds to triplet 2 from left to right in the sequence given above. (2)

- 2.2 The diagrams below show a pair of homologous chromosomes during meiosis. Diagram I show the whole chromosomes and Diagram II is an enlarged view of the section encircled in Diagram I.

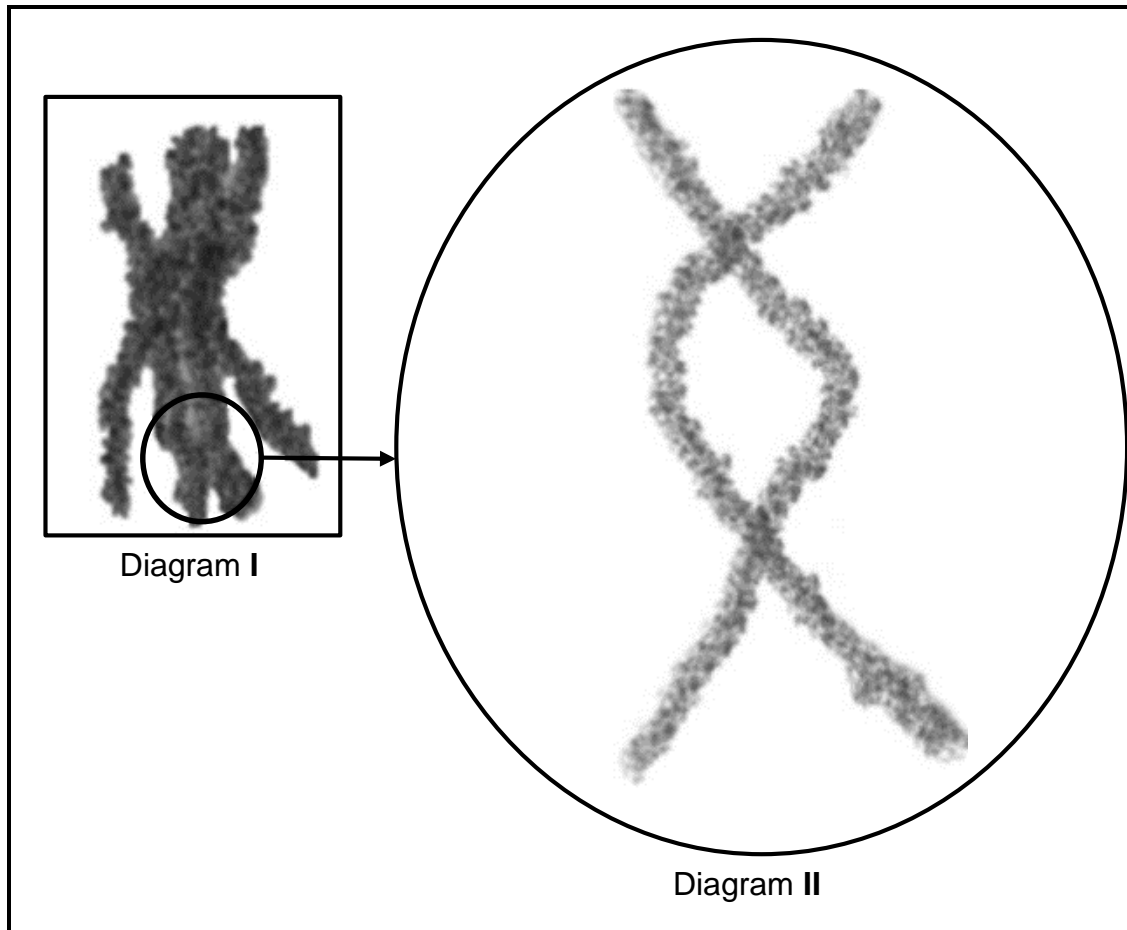

- 2.2.1 Name the phase during meiosis that would be occurring for this arrangement of chromosomes to be observed. (1)
- 2.2.2 Name and describe the process occurring in the circled area in Diagram I. (5)
- 2.2.3 Explain the significance of the process mentioned in QUESTION 2.2.2 for gametogenesis. (2)

- 2.3 Haemophilia is a sex-linked genetic condition caused by a recessive allele carried on the X chromosome (X^h). The following diagram shows a portion of a family in which some members have haemophilia. Haemophiliac individuals are shaded in the diagram.

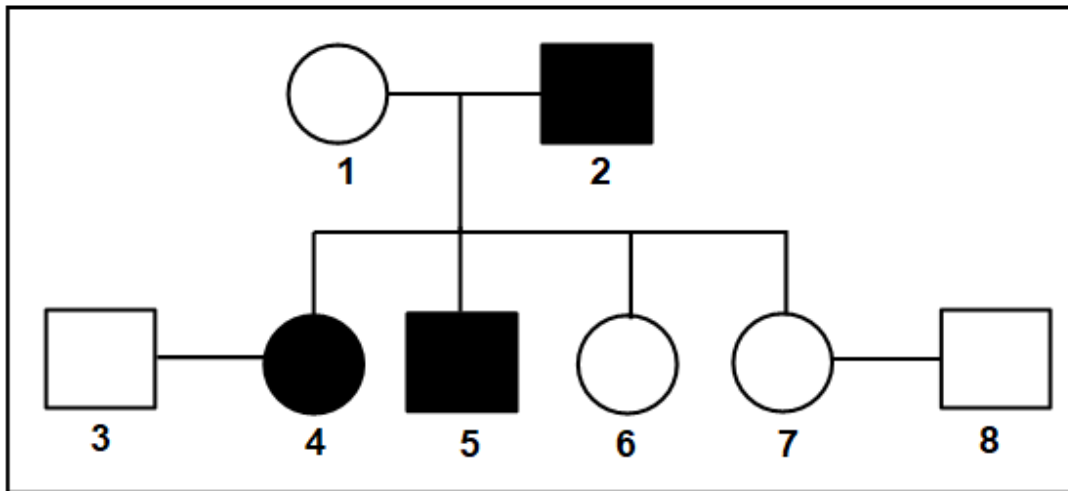

- 2.3.1 Name the type of diagram shown above. (1)
- 2.3.2 How many:
- (a) Children are males (1)
- (b) Males have haemophilia (1)
- 2.3.3 Use appropriate letters to indicate the genotype of each of the following:
- (a) Individual 1 (1)
- (b) Individual 2 (1)
- 2.3.4 Use a genetic cross to show the percentage chance of individual 7 who is heterozygous and individual 8 producing a son with haemophilia. (6)

- 2.4 The graph below shows the results of the degree of convexity of a participant's lens measured over a period of time.

During the time indicated, the participant was asked to look at an object which could be moved closer to or further away from the participant.

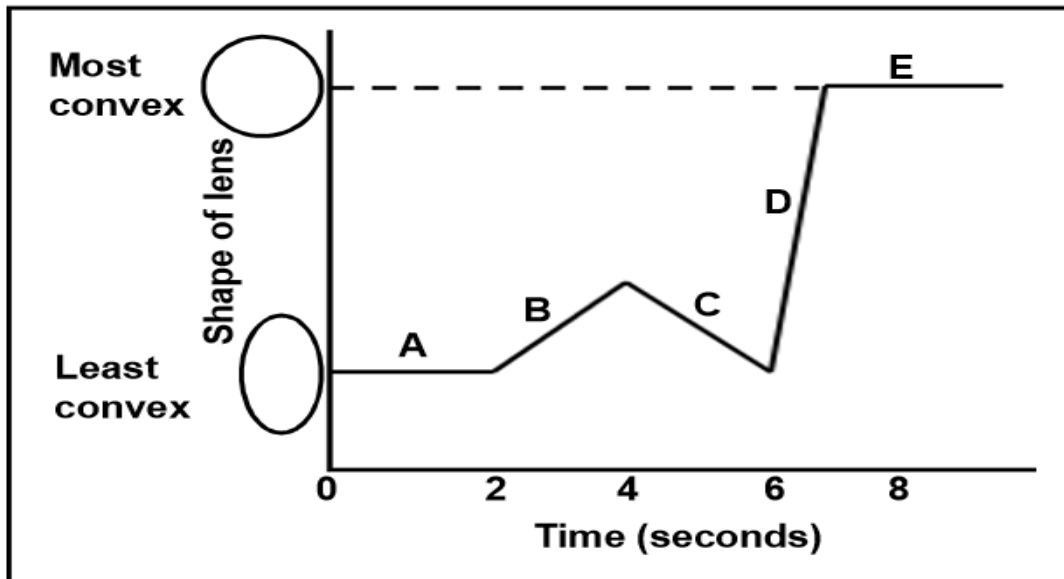

- 2.4.1 Name the process that changed the shape of the lens. (1)
- 2.4.2 Give the LETTER on the graph that indicates the period of time during the investigation when the object was:
- (a) Moving towards the participant (1)
- (b) Closest to the participant (1)
- 2.4.3 Describe how a clear image is maintained during period **C** on the graph. (4)

2.5 Below is a diagram showing the development of the follicle leading to the production of the structure that produced structure **A**.

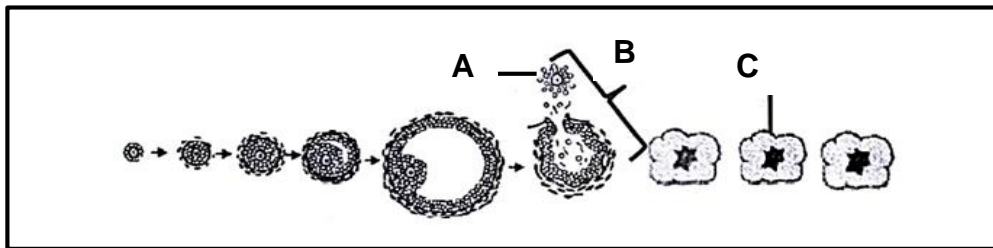

2.5.1 Identify:

- (a) Structure **C** (1)
- (b) Process **B** (1)

2.5.2 Name the hormone produced by the follicle before process **B**. (1)

2.5.3 Explain the consequence in a 25-year-old female with regard to the ovarian cycle if her pituitary gland does not secrete hormones. (4)

2.5.4 Explain the importance of structure **C** remaining constant after process **B**. (3)

[50]

QUESTION 3

3.1 The diagram below shows the structure of the human ear.

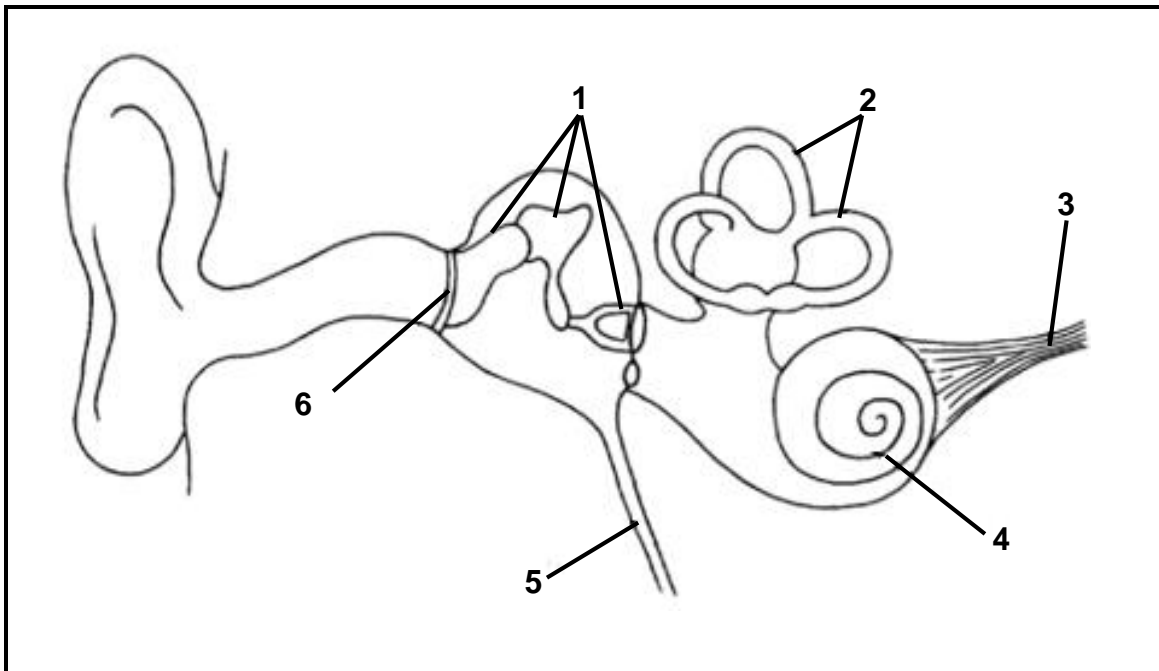

- 3.1.1 Identify parts labelled **2** and **3**. (2)
- 3.1.2 Give ONE function of each of the parts labelled **5** and **6**. (2)
- 3.1.3 Describe the role played by part labelled **2**, in maintaining balance when the position of the head changes. (5)
- 3.1.4 If structures labelled **1** were not attached to each other, briefly explain the impact this would have on hearing. (3)

3.2 Read the extract below.

The European corn borer moth, *Ostrinia nubilalis*, is a pest. Its larvae develop inside maize stems and eat the contents, weakening the stems so that the plants collapse.

The bacterium, *Bacillus thuringiensis* ('Bt'), produces a protein that poisons the larvae of moths and butterflies. This can be isolated from cultures of Bt and packaged in fluids to be sprayed on surface of plants.

The gene coding for the toxic protein has also been isolated and incorporated into a genetically modified strain of maize called Bt corn. This makes the plant tissues to be poisonous to the corn borer moth.

- 3.2.1 Describe ONE disadvantage of European corn borer moth in plants. (2)
- 3.2.2 A farmer wants to increase the yield of maize.
Explain why you would not recommend spraying the unmodified corn with Bt toxin. (3)

- 3.2.3 Some scientists investigated the different ways of protecting maize against the corn borer moth.

The method they followed is described below:

- Several hundreds of maize seedlings were planted in three separate but close together plots, in the same field
- The seedlings in the three plots were treated as follows:
 - **Plot A** was untreated
 - **Plot B** was sprayed daily with Bt toxin
 - **Plot C** the seedlings planted were genetically modified Bt corn
- On the first day of each week, one scientist would walk around the edge of a plot and count the number of maize plants that had collapsed
- Each plot had a scientist responsible for counting

The results are shown in the table below.

Week number	Number of maize plants collapsed since the last weekly count		
	Plot A	Plot B	Plot C
1	0	0	1
2	0	0	0
3	18	22	21
4	0	0	0
5	5	1	0
6	14	11	12
7	5	2	1
8	12	0	1
9	17	1	0
10	30	6	0
11	32	13	1
12	41	17	0

State the:

- (a) Independent variable (1)
- (b) Dependent variable (1)
- 3.2.4 Why was Plot **A** included in the investigation? (2)
- 3.2.5 Calculate the average number of maize plants collapsed in Plots **B** and **C** respectively. (4)

3.2.6 Based on the calculations done in QUESTION 3.2.5, what conclusions can be drawn with regards to the effectiveness of the method followed in Plot **B** and **C** in protecting maize against the corn borer moth. (2)

3.2.7 State TWO ways in which the scientists ensured reliability of this investigation. (2)

3.2.8 Describe ONE way in which this investigation is invalid. (1)

3.3 The diagram below shows parts of the human nervous system.

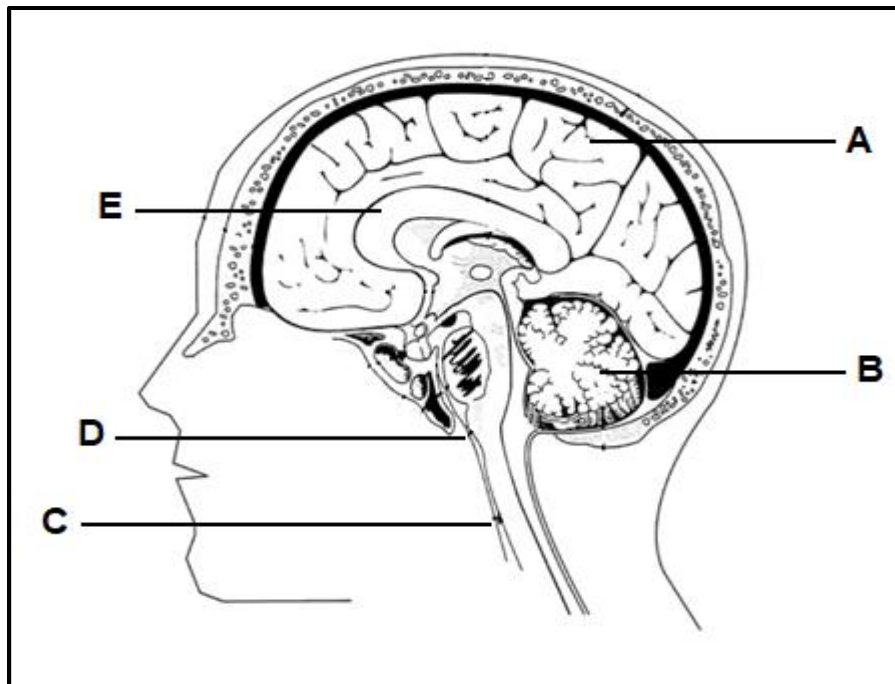

3.3.1 Give TWO reasons why humans need a nervous system. (2)

3.3.2 Give the LETTER and NAME of the part that has the following function:

(a) Allows communication between cerebral hemispheres (2)

(b) Controls reflex actions (2)

3.3.3 Explain each of the following observations by referring to the function and the part of the brain indicated:

(a) Damage to part labelled **D** results in death, even if all the other parts of the brain and the body are functioning (2)

(b) A blood clot in the right half of the part labelled **A** may result in paralysis in the left arm (2)

3.4 The diagram below represents a developing foetus in a human body.

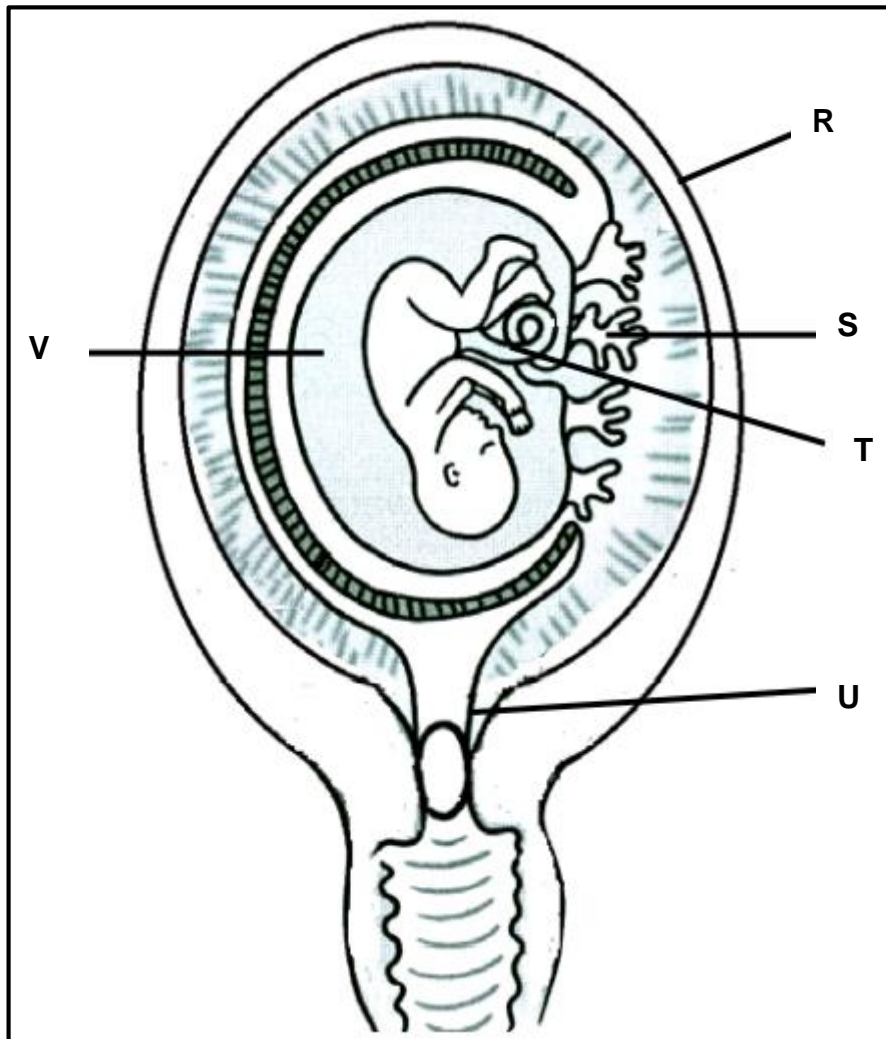

3.4.1 Identify:

- (a) **S** (1)
- (b) **T** (1)

3.4.2 State ONE function of the fluid labelled **V**. (1)

3.4.3 Name TWO systems in the baby's body that take over the function of part **S** once the baby is born. (2)

3.4.4 Tabulate ONE difference in the composition of the blood in a vein and in an artery found in structure **T**. (3)

3.4.5 Explain what prevents another ovum being produced while the foetus is developing in a human body. (2)

[50]

TOTAL SECTION B: 100
GRAND TOTAL: 150